



认证号: E133481



认证号: R50147087



认证号: CQC09002030026 (DC型)
CQC09002030027 (AC型)

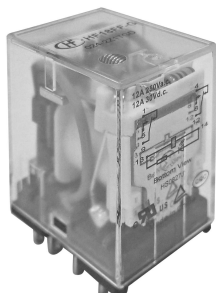

特性

- 多种类型继电器, 包括内置发光二极管
- 具有二、三、四组转换触点形式
- 具有多种引出脚方式
- 镀金触点型
- 透明防尘罩、多种安装方式
- 自动化生产
- 高负载

触点参数

触点形式	2Z, 3Z, 4Z
接触电阻 ⁽¹⁾	≤100mΩ (1A 6VDC)
触点材料	详见订货标记
触点负载(阻性)	12A 250VAC/30VDC (2Z-G)
	10A 250VAC/30VDC (3Z-G)
	7A 250VAC/30VDC (2Z/3Z)
	6A 250VAC/30VDC (4Z)
最大切换电压	250VAC / 30VDC
最大切换电流	12A (2Z-G), 10A (3Z-G), 7A (2Z/3Z), 6A (4Z)
最大切换功率	3000VA/360W (2Z-G), 2500VA/300W (3Z-G) 1750VA/210W (2Z/3Z), 1500VA/180W (4Z)
机械耐久性	2 × 10 ⁷ 次
电耐久性 ⁽²⁾	1 × 10 ⁵ 次(室温)

备注: (1) 上述值均为初始值;

(2) 详细电耐久性信息情况请见性能曲线图, 如有其他条件需求, 可与我司联系。

性能参数

绝缘电阻	1000MΩ (500VDC)	
介质耐压	线圈与触点间	1500VAC 1min
	断开的触点间	1000VAC 1min
	触点组之间	1500VAC 1min
动作时间(额定电压下)	≤20ms	
释放时间(额定电压下)	15ms(DC型), ≤25ms(DC带续流二极管型) ≤25ms(AC型)	
线圈温升 ⁽²⁾	≤85K	
冲击	稳定性	100m/s ²
	强度	1000m/s ²
振动	10Hz ~ 55Hz 1mm 双振幅	
湿度	5%~85% RH	
温度范围	-40°C ~ 70°C	
引出端形式	印制板式、插入式	
重量	约35.6g	
封装方式	防尘罩型	

备注: (1) 上述值均为初始值;

(2) 温升测试时, 需单只测试。

线圈参数

额定线圈功率	DC型: 约(0.8 ~ 1.1)W; AC型: 约(0.9 ~ 1.5)VA
--------	--

线圈规格表

23°C

额定电压 VDC	动作电压 ⁽¹⁾ VDC	释放电压 VDC	最大电压 ⁽²⁾ VDC	线圈电阻 Ω
5	≤4.0	≥0.50	5.5	28 x (1±10%)
6	≤4.8	≥0.60	6.6	40 x (1±10%)
9	≤7.2	≥0.90	9.9	90 x (1±10%)
12	≤9.6	≥1.20	13.2	160 x (1±10%)
21	≤16.8	≥2.10	23.1	490 x (1±10%)
24	≤19.2	≥2.40	26.4	640 x (1±10%)
30	≤24.0	≥3.00	33.0	1000 x (1±10%)
36	≤28.8	≥3.60	39.6	1440 x (1±10%)
48	≤38.4	≥4.80	52.8	2560 x (1±15%)
60	≤48.0	≥6.00	66.0	4000 x (1±15%)
110 ⁽³⁾	≤80.0	≥11.0	121.0	12250 x (1±15%)
125 ⁽³⁾	≤100.0	≥12.5	137.5	17360 x (1±15%)
220	≤176.0	≥22.0	242.0	53360 x (1±15%)

额定电压 VAC	动作电压 ⁽¹⁾ VAC	释放电压 VAC	最大电压 ⁽²⁾ VAC	线圈电阻 Ω
6	≤4.80	≥1.80	6.6	11 x (1±10%)
12	≤9.60	≥3.60	13.2	44 x (1±10%)
24	≤19.2	≥7.20	26.4	177 x (1±10%)
36	≤28.8	≥10.8	39.6	400 x (1±10%)
48	≤38.4	≥14.4	52.8	708 x (1±10%)
60	≤48.0	≥18.0	66.0	1100 x (1±10%)
110 ⁽³⁾	≤80.0	≥33.0	121	3400 x (1±15%)
120 ⁽³⁾	≤88.0	≥36.0	132	4080 x (1±15%)
220 ⁽³⁾	≤160.0	≥66.0	242	13600 x (1±15%)
230	≤176.0	≥72.0	253	16300 x (1±15%)
240 ⁽³⁾	≤176.0	≥72.0	264	16300 x (1±15%)
277	≤221.6	≥83.1	304.7	23590 x (1±15%)

备注: (1) 常温下, 让继电器正常动作时, 需要在继电器的线圈脚施加电压的最小值不得低于额定电压值的80%, 但为了达到规定的产品性能, 使用时请对线圈施加额定电压;

(2) 最大电压是指继电器线圈在短时间能够承受的最大电压值;

(3) A110: 额定电压(100~110)V.a.c.; A120: 额定电压(110~120)V.a.c.; A220: 额定电压(200~220)V.a.c.; A240: 额定电压(220~240)V.a.c.; 110: 额定电压(100~110)V.d.c.; 125: 额定电压(110~125)V.d.c.;

(4) 240Va.c.测试线圈温升时, 安装间距需≥6mm。



宏发继电器

ISO9001、ISO/TS16949、ISO14001、OHSAS18001、IECQ QC080000 认证企业

2020 Rev. 1.01

安全认证

UL/CUL	2Z-G	12A 250VAC/30VDC,阻性, 70°C
	3Z-G	10A 250VAC/30VDC阻性, 70°C
	2Z/3Z	7A 250VAC/30VDC阻性, 70°C
	4Z	6A 250VAC/30VDC阻性, 70°C
TÜV	2Z-G	12A 250VAC/30VDC
	3Z-G	10A 250VAC/30VDC
	2Z/3Z	7A 250VAC/30VDC
	4Z	6A 250VAC/30VDC
CQC	2Z-G	12A 250VAC/30VDC
	3Z-G	10A 250VAC/30VDC
	2Z/3Z	7A 250VAC/30VDC
	4Z	6A 250VAC/30VDC

备注: (1) 表中未注明温度的负载, 均指环境温度为室温;

(2) 以上仅列出了该产品认证的部分典型负载, 每个负载的详细测试条件不同, 因此电耐久性寿命次数不一样, 如需了解详细信息, 请与我司联系。

订货标记示例

	HF18FF	-G	/A	240	-2Z	1	3	G	D	(XXX)
继电器型号	HF18FF : 无按钮型 HF18FH : 带按钮型									
系列代号	空白: 标准型 G ⁽¹⁾ : 高负载型									
线圈电源	A : 交流 (50HZ或60HZ) 无: 直流									
线圈电压	直流 ⁽²⁾ : 005 ~ 220VDC 交流 ⁽³⁾ : 006 ~ 277VAC									
触点形式	2Z : 两组转换	3Z : 三组转换	4Z : 四组转换							
安装形式	1 : 插入式	2 : 印制板式	5 ⁽⁴⁾ : 插入式带法兰							
触点材料	3 : AgNi T : AgSnO ₂									
镀层代号	无: 不镀金 G : 镀金									
组合元件代号	无: 不带组合元件 D : 带LED J : 带续流二极管 R : 带CR板 DJ : 带LED、带续流二极管 DR : 带LED、带CR板									
特性号 ⁽⁵⁾	XXX : 客户特殊要求 无: 标准型									

备注: (1) "-G"高负载型只具有2Z和3Z两种触点形式, 不具有4Z触点形式;

(2) 直流线圈规格: 005、006、009、012、021、024、030、036、048、060、110、125、220;

(3) 交流线圈规格: 006、012、024、036、048、060、110、120、220、230、240、277;

(4) HF18FH不具有插入式带法兰安装形式, 下单时请使用HF18FF型号;

(5) 客户特殊要求由我司评审后, 按特性号的形式标识;

(6) 可提供(136)低成本型继电器, 具体性能以规格书为准, 如需了解详细信息, 请与我司联系;

(7) 对于110VDC及以上的线圈规格建议客户在电路中增加线圈保护措施。

外形图

HF18FF-□/□□-2Z1□□□□

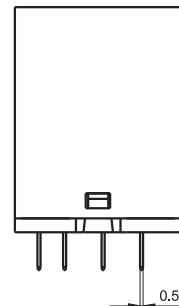
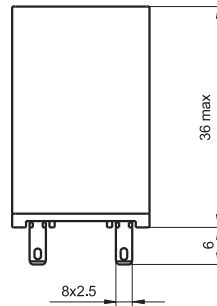
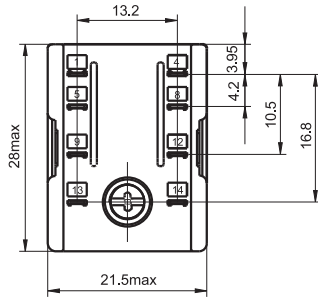

HF18FF-□/□□-2Z2□□□□

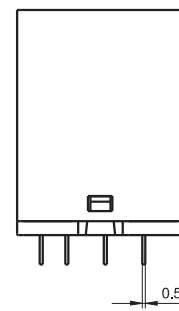
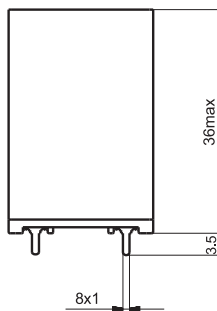
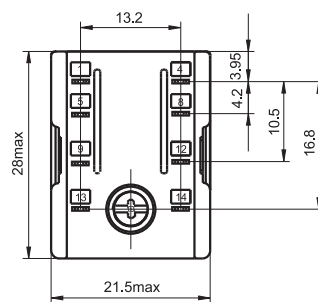

HF18FF-□/□□-2Z5□□□□

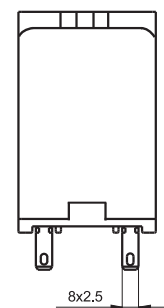
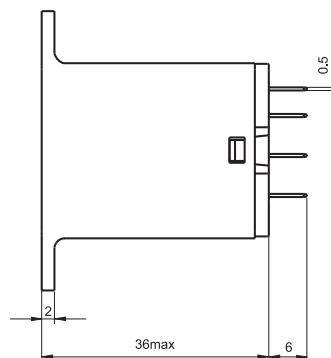
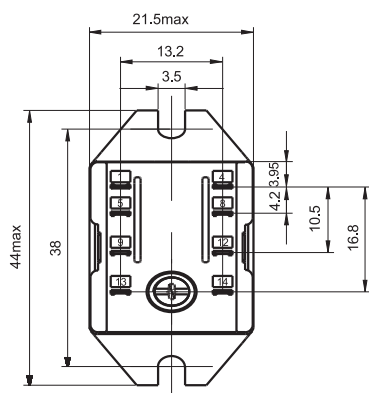

外形图

HF18FF-□/□□-3Z1□□□□

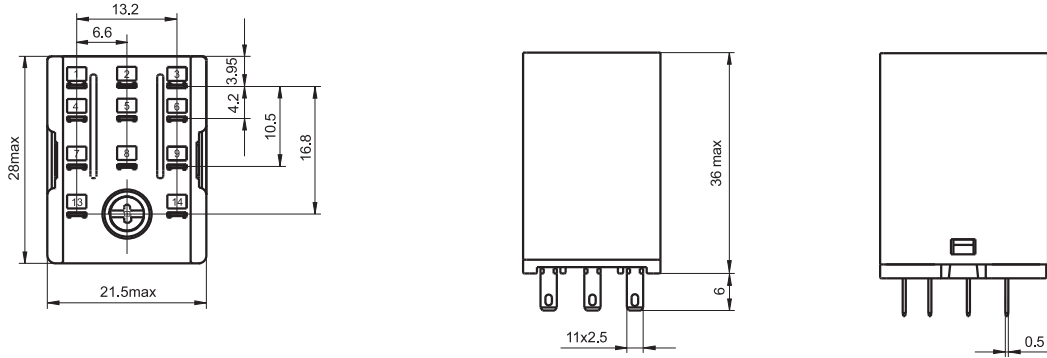

HF18FF-□/□□-3Z2□□□□

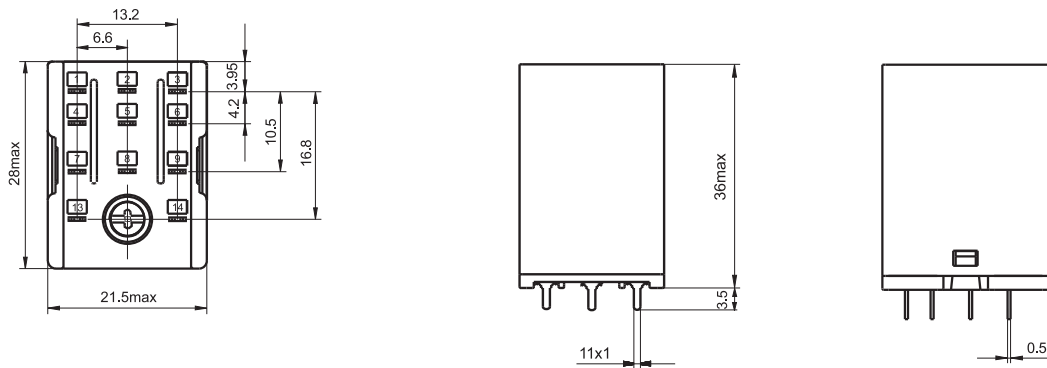

HF18FF-□/□□-3Z5□□□□

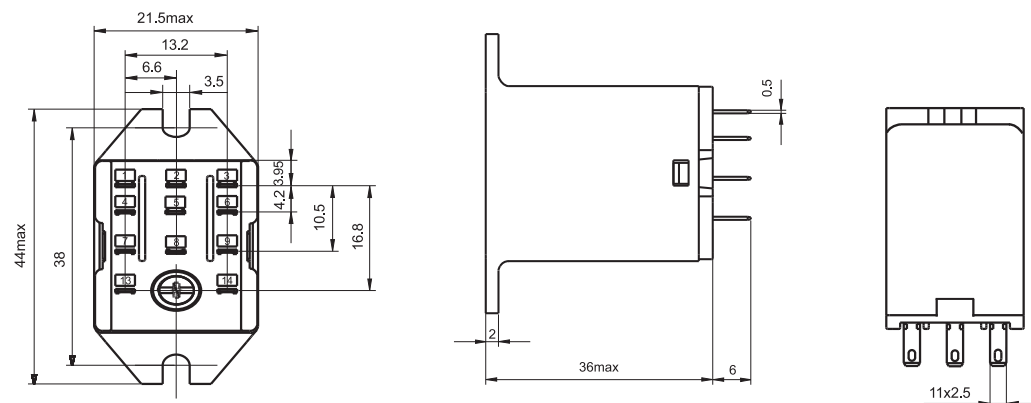

外形图

HF18FF-□/□□-4Z1□□□□

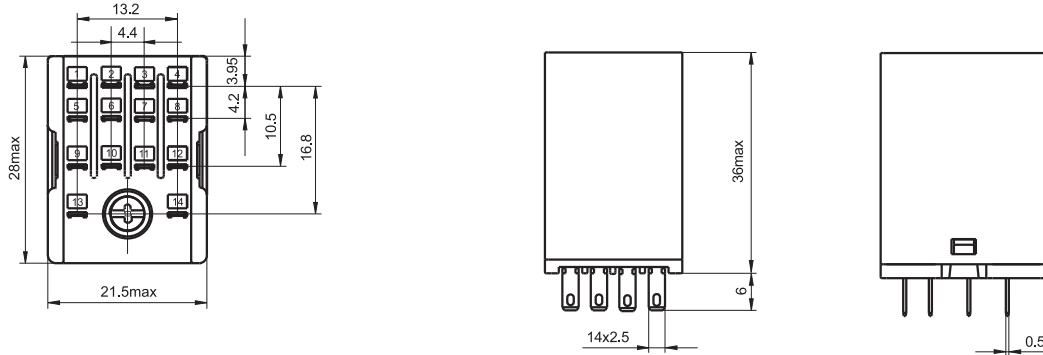

HF18FF-□/□□-4Z2□□□□

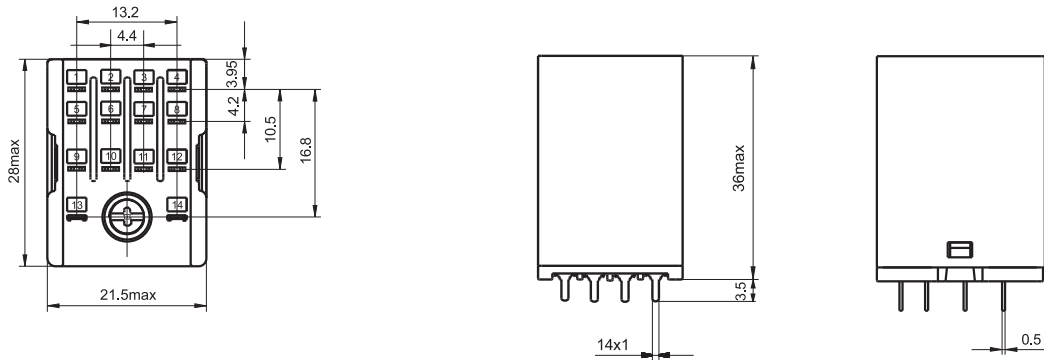

HF18FF-□/□□-4Z5□□□□

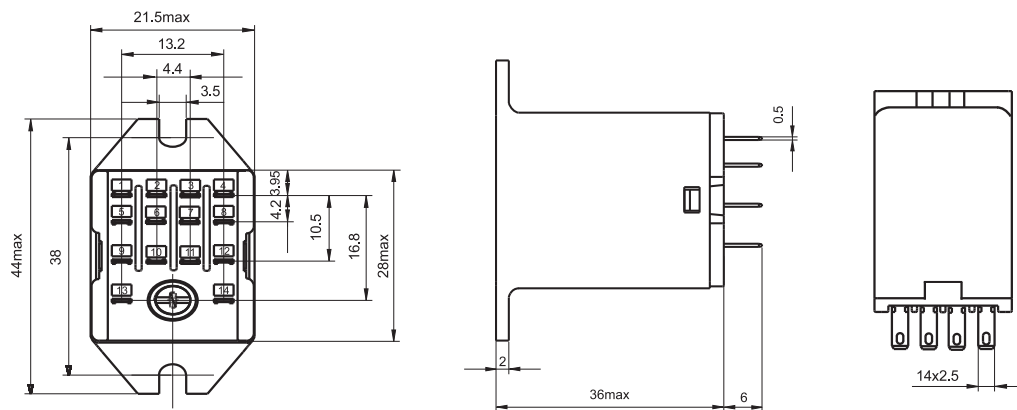

外形图

HF18FH-□/□□-2Z1□□□□

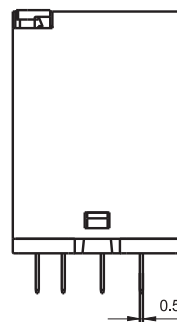
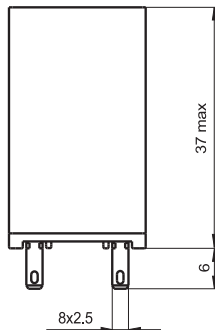
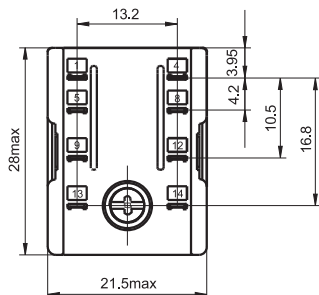

HF18FH-□/□□-2Z2□□□□

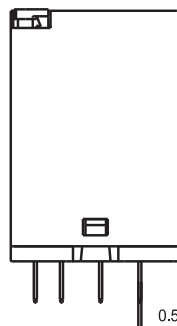
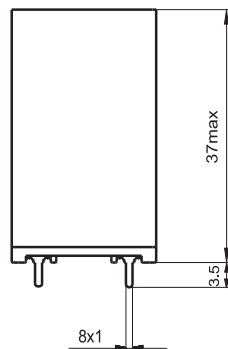
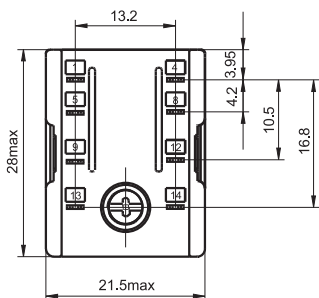

HF18FH-□/□□-3Z1□□□□

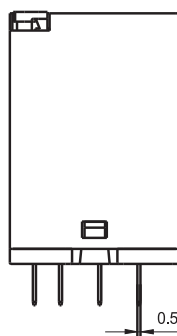
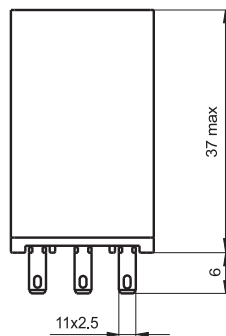
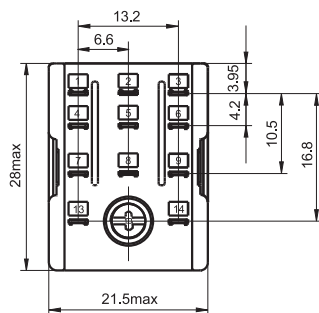

外形图

HF18FH-□/□□-3Z2□□□□

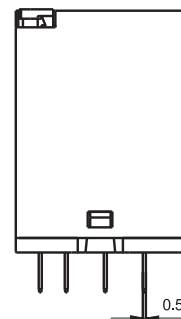
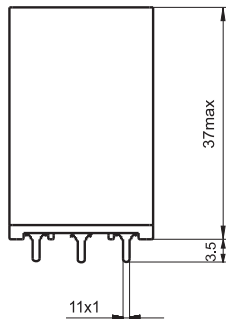
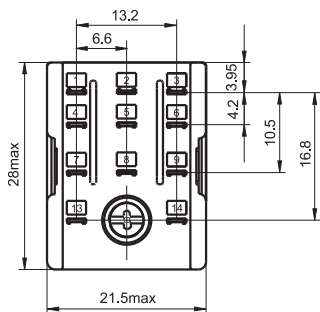

HF18FH-□/□□-4Z1□□□□

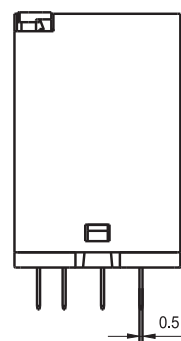
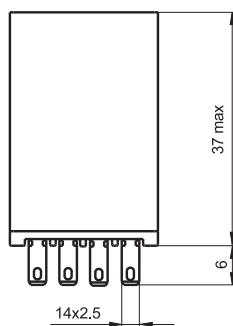
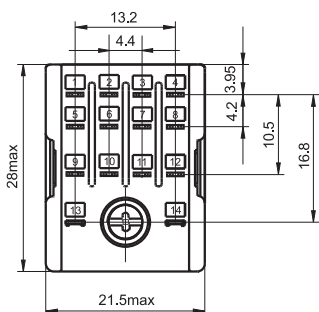

HF18FH-□/□□-4Z2□□□□

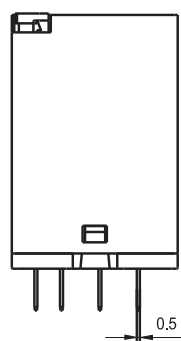
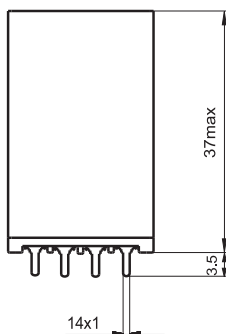
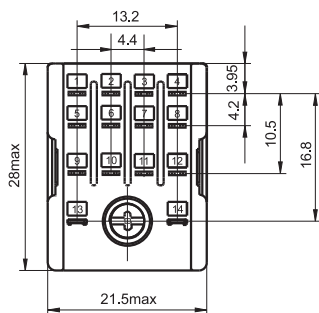

安装孔尺寸
(底视图)

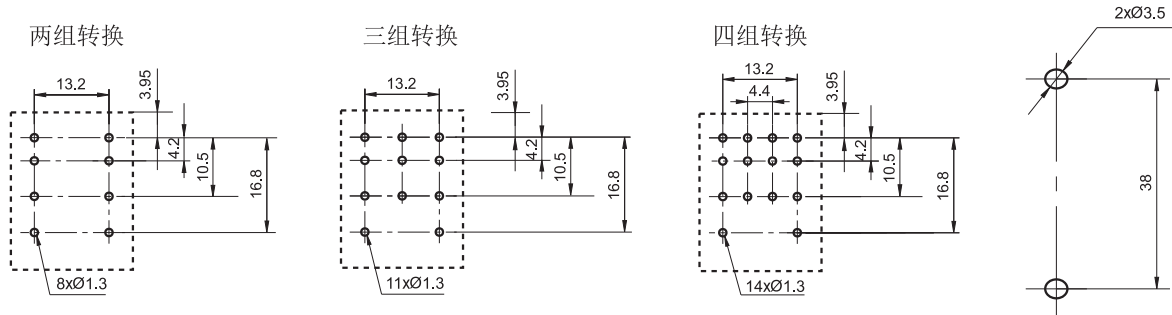

接线图
(底视图)

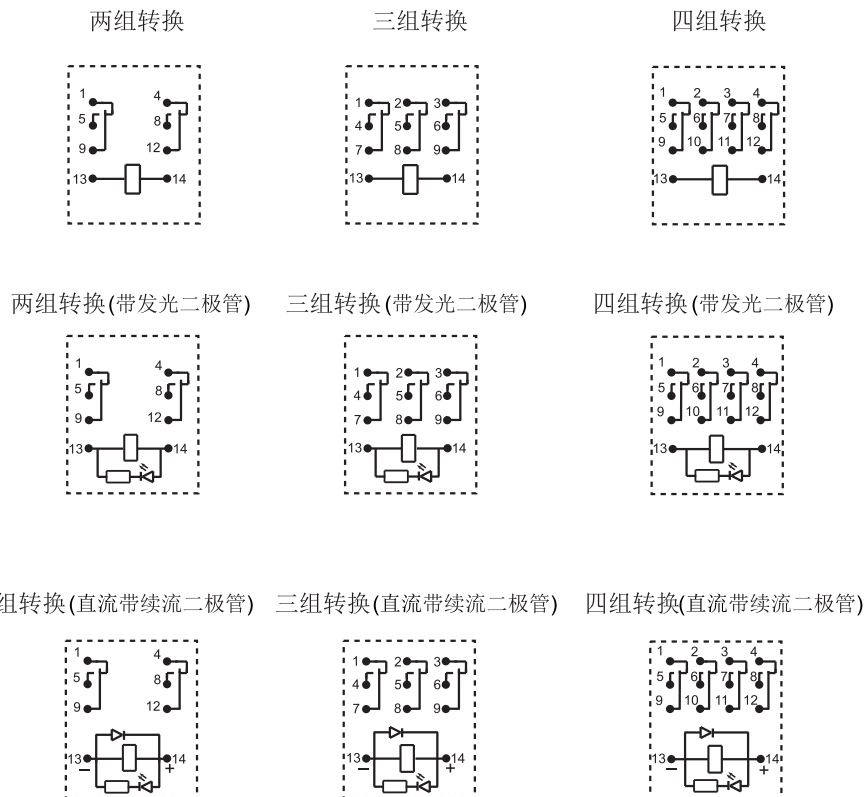

备注: (1) 产品部分外形尺寸未注尺寸公差, 当外形尺寸 $\leq 1\text{mm}$, 公差为 $\pm 0.2\text{mm}$; 当外形尺寸在 $(1 \sim 5)\text{mm}$ 之间时, 公差为 $\pm 0.3\text{mm}$; 当外形尺寸 $> 5\text{mm}$, 公差为 $\pm 0.4\text{mm}$;
 (2) 安装孔尺寸中未注尺寸公差为 $\pm 0.1\text{mm}$;
 (3) 直流带续流二极管产品在接线前需确认正负极。

性能曲线图

最大切换功率
(2Z-G)

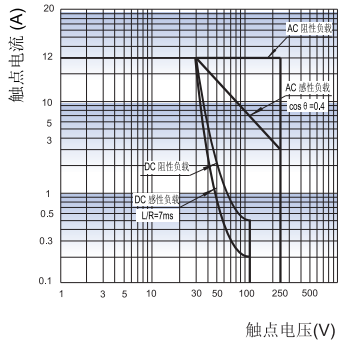

最大切换功率
(3Z-G)

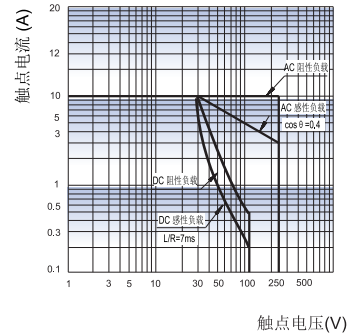

最大切换功率
(2Z/3Z)

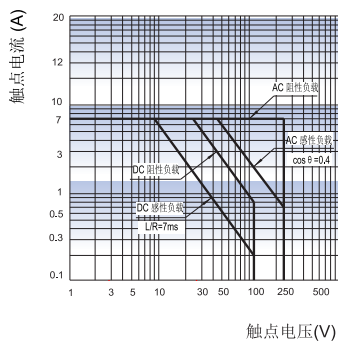

最大切换功率
(4Z)

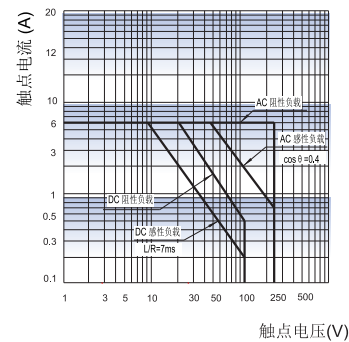

继电器配套插座



特性

- 介质耐压可达2000VAC，绝缘电阻1000MΩ
- PCB式、螺钉式、导轨式安装形式可供选择
- 带手指保护功能插座可供选择
- 多款插入式模块可供选择，实现通电指示、线路保护等功能
- 可选用配件：卡簧、标识板、插入式模块
- 环保产品（符合RoHS）



性能参数

插座型号	额定电压	额定电流	环境温度	介质耐压min.	螺钉扭矩	剥露导线长度	重量
18FF-2Z-A2	250VAC	7A	-40℃ ~ 70℃	2000VAC	—	—	约8g
18FF-2Z-C1	250VAC	7A	-40℃ ~ 70℃	2000VAC	0.8N·m	7mm	约35g
18FF-2Z-C2	250VAC	7A	-40℃ ~ 70℃	2000VAC	0.8N·m	7mm	约36g
18FF-2Z-C4	250VAC	7A	-40℃ ~ 70℃	2000VAC	0.6N·m	7mm	约53g
18FF-2Z-C5	250VAC	7A	-40℃ ~ 70℃	2000VAC	0.6N·m	7mm	约64g
18FF-2Z-C8	250VAC	7A	-40℃ ~ 70℃	2000VAC	0.6N·m	7mm	约41g
18FF-2Z-C9	250VAC	7A	-40℃ ~ 70℃	2000VAC	—	7mm	约70g
18FF-3Z-C4	250VAC	7A*	-40℃ ~ 70℃	2000VAC	0.6N·m	7mm	约59g
18FF-3Z-C5	250VAC	7A*	-40℃ ~ 70℃	2000VAC	0.6N·m	7mm	约71g
18FF-4Z-A2	250VAC	7A*	-40℃ ~ 70℃	2000VAC	—	—	约8g
18FF-4Z-C1	250VAC	7A*	-40℃ ~ 70℃	2000VAC	0.8N·m	7mm	约58g
18FF-4Z-C2	250VAC	7A*	-40℃ ~ 70℃	2000VAC	0.8N·m	7mm	约59g
18FF-4Z-C4	250VAC	7A*	-40℃ ~ 70℃	2000VAC	0.6N·m	7mm	约64g
18FF-4Z-C5	250VAC	7A*	-40℃ ~ 70℃	2000VAC	0.6N·m	7mm	约76g
18FF-4Z-C8	250VAC	7A*	-40℃ ~ 70℃	2000VAC	0.6N·m	7mm	约51g
18FF-4Z-C9	250VAC	7A*	-40℃ ~ 70℃	2000VAC	—	7mm	约81g
18FZ-2Z-C2	250VAC	7A	-40℃ ~ 70℃	2000VAC	0.8N·m	7mm	约30g
18FZ-4Z-C2	250VAC	5A	-40℃ ~ 70℃	2000VAC	0.8N·m	7mm	约44g
18FF-2Z-C1(734)	250VAC	12A	-40℃ ~ 70℃	2000VAC	0.8N·m	7mm	约35g
18FF-2Z-C2(734)	250VAC	12A	-40℃ ~ 70℃	2000VAC	0.8N·m	7mm	约36g
18FF-2Z-C4(734)	250VAC	12A	-40℃ ~ 70℃	2000VAC	0.6N·m	7mm	约53g
18FF-2Z-C5(734)	250VAC	12A	-40℃ ~ 70℃	2000VAC	0.6N·m	7mm	约64g
18FF-3Z-C5(734)	250VAC	10A	-40℃ ~ 70℃	2000VAC	0.6N·m	7mm	约71g

备注：“*”的插座型号，各组电流总和不得超过20A。



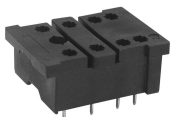
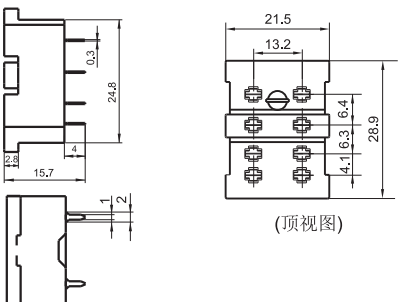
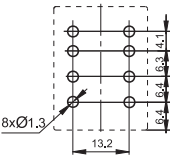

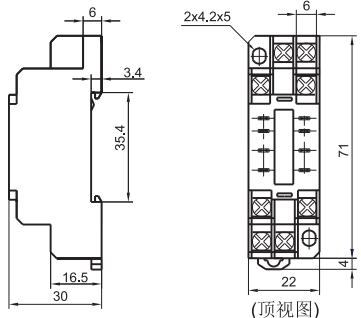
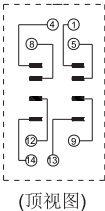
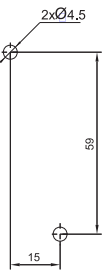

外形图、接线图、安装孔尺寸

单位: mm

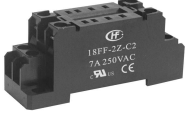
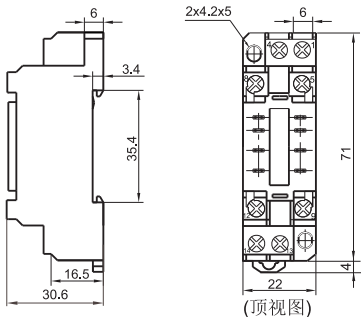
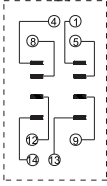
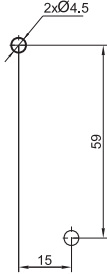
插座	外形尺寸	接线图	安装孔尺寸	可选配件
<p>18FF-2Z-A2</p>  <p>印制板式引出端、 印制板式安装 适用于两组的继电器产品</p>	 <p>(顶视图)</p>		 <p>金属卡簧 18FF-H1</p>	
<p>18FF-2Z-C1 18FF-2Z-C1(734)</p>  <p>螺钉式引出端、 导轨或螺钉式安装 不带手指保护结构 适用于两组的继电器产品</p>	 <p>(顶视图)</p>	 <p>(顶视图)</p>	 <p>金属卡簧 18FF-H2 (成对配合使用)</p>	

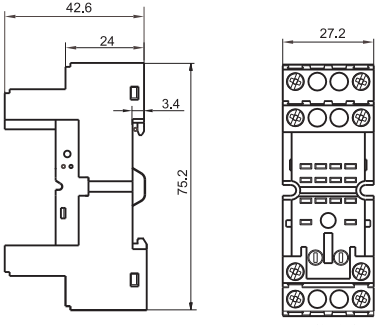
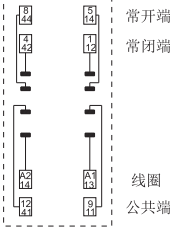
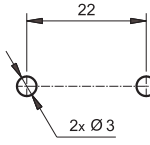

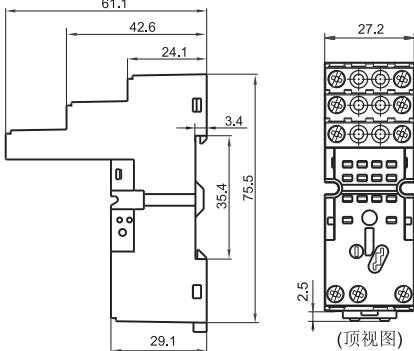
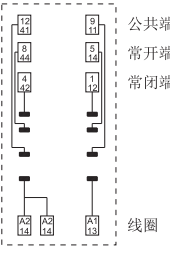
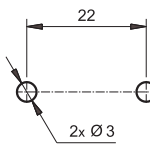

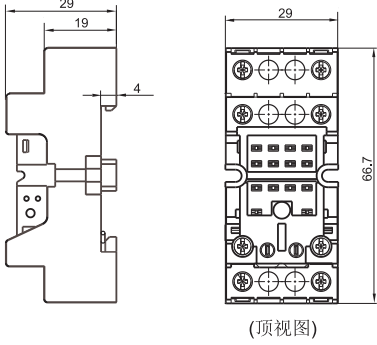
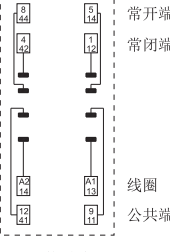
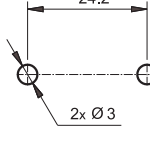
外形图、接线图、安装孔尺寸





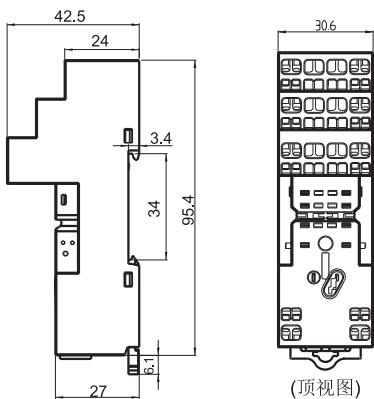
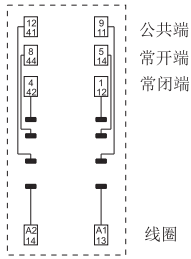

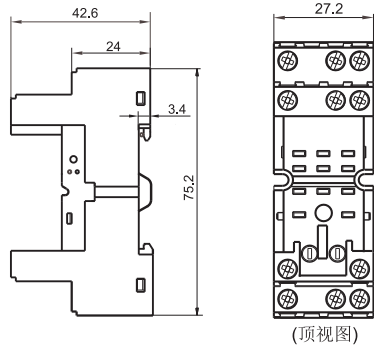
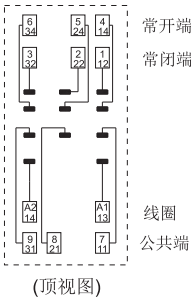
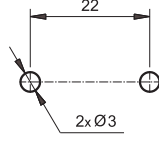
单位: mm

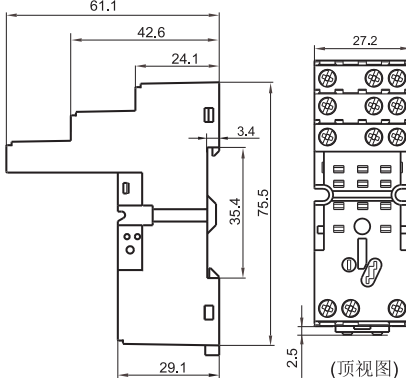
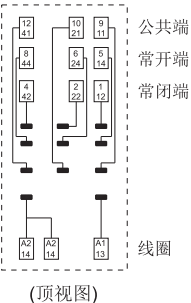
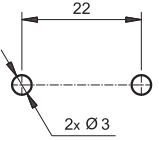
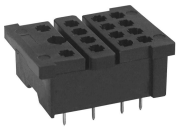
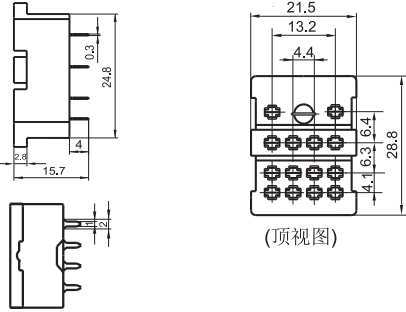
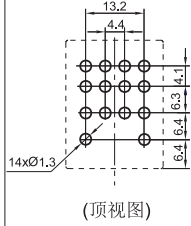
插座	外形尺寸	接线图	安装孔尺寸	可选配件
<p>18FF-2Z-C2 18FF-2Z-C2(734)</p>  <p>螺钉式引出端、 导轨式或螺钉式安装、 带手指保护结构 适用于两组的继电器产品</p>	 <p>(顶视图)</p>	 <p>(顶视图)</p>		<p>金属卡簧 18FF-H2 (成对配合使用)</p>
<p>18FF-2Z-C4 18FF-2Z-C4(734)</p>  <p>螺钉式引出端、 导轨式或螺钉式安装、 带手指保护结构 适用于两组的继电器产品</p>	 <p>(顶视图)</p>	 <p>(顶视图)</p>		<p>塑料卡簧 18FF-H4 金属卡簧 18FF-H5 标识板 18FF-M1 插入式模块 HFAA ~ HFHU*</p>
<p>18FF-2Z-C5 18FF-2Z-C5(734)</p>  <p>螺钉式引出端、 导轨式或螺钉式安装、 带手指保护结构 适用于两组的继电器产品</p>	 <p>(顶视图)</p>	 <p>(顶视图)</p>		<p>塑料卡簧 18FF-H4 金属卡簧 18FF-H5 标识板 18FF-M1 插入式模块 HFAA ~ HFHU*</p>
<p>18FF-2Z-C8</p>  <p>螺钉式引出端、 导轨式或螺钉式安装、 带手指保护结构 适用于两组的继电器产品</p>	 <p>(顶视图)</p>	 <p>(顶视图)</p>		<p>塑料卡簧 18FF-H4 金属卡簧 18FF-H5 标识板 18FF-M3 插入式模块 HFAA ~ HFHU*</p>

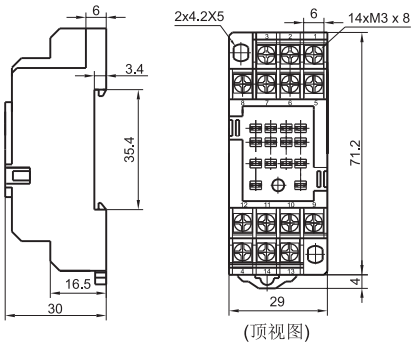
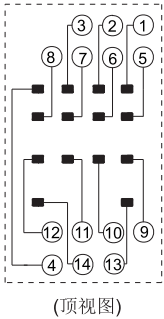
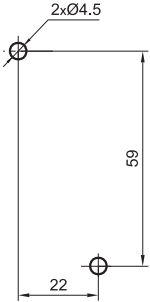
外形图、接线图、安装孔尺寸

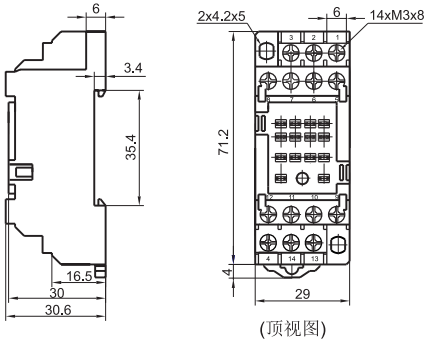
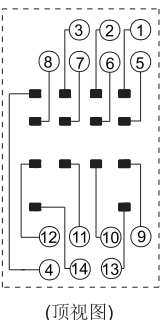
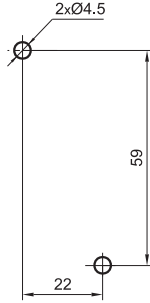

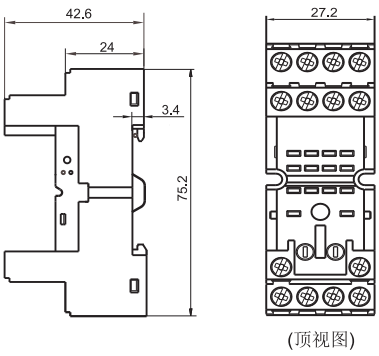
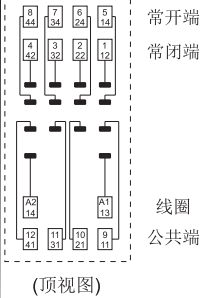
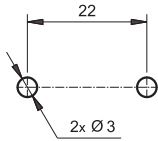

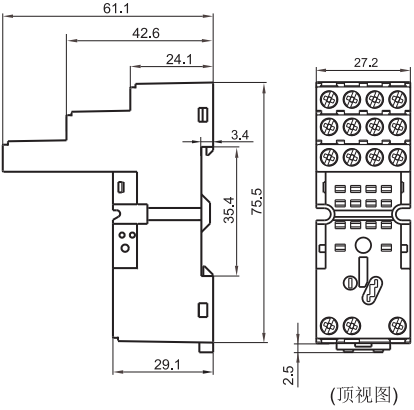
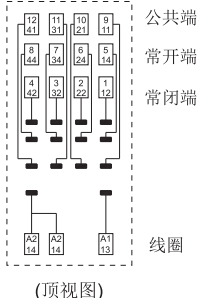
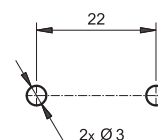

单位: mm

插座	外形尺寸	接线图	安装孔尺寸	可选配件
<p>18FF-2Z-C9</p>  <p>弹簧式引出端、 导轨式安装、 带手指保护结构 适用于两组的继电器产品</p>	 <p>(顶视图)</p>	 <p>(顶视图)</p>		<p>塑料卡簧 18FF-H4</p> <p>金属卡簧 18FF-H5</p> <p>插入式模块 HFAA ~ HFHU*</p> <p>标识板 18FF-M3</p>
<p>18FF-3Z-C4</p>  <p>螺钉式引出端、 导轨式或螺钉式安装、 带手指保护结构 适用于三组的继电器产品</p>	 <p>(顶视图)</p>	 <p>(顶视图)</p>	 <p>(顶视图)</p>	<p>塑料卡簧 18FF-H4</p> <p>金属卡簧 18FF-H5</p> <p>标识板 18FF-M1</p> <p>插入式模块 HFAA ~ HFHU*</p>
<p>18FF-3Z-C5 18FF-3Z-C5(734)</p>  <p>螺钉式引出端、 导轨式或螺钉式安装、 带手指保护结构 适用于三组的继电器产品</p>	 <p>(顶视图)</p>	 <p>(顶视图)</p>	 <p>(顶视图)</p>	<p>塑料卡簧 18FF-H4</p> <p>金属卡簧 18FF-H5</p> <p>标识板 18FF-M1</p> <p>插入式模块 HFAA ~ HFHU*</p>
<p>18FF-4Z-A2</p>  <p>印制板式引出端、 印制板式安装 适用于四组的继电器产品</p>	 <p>(顶视图)</p>		 <p>(顶视图)</p>	<p>金属卡簧 18FF-H1</p>

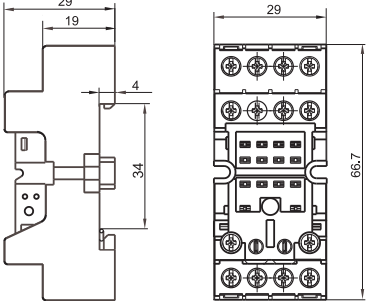
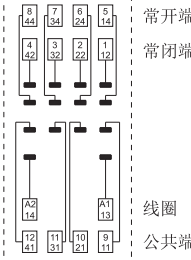
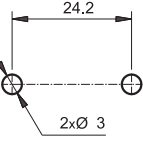
插座	外形尺寸	接线图	安装孔尺寸	可选配件
<p>18FF-4Z-C1</p>  <p>螺钉式引出端、 导轨式或螺钉式安装 不带手指保护结构 适用于四组的继电器产品</p>	 <p>(顶视图)</p>	 <p>(顶视图)</p>		<p>金属卡簧 18FF-H2 (成对配合使用)</p>
<p>18FF-4Z-C2</p>  <p>螺钉式引出端、 导轨式或螺钉式安装、 带手指保护结构 适用于四组的继电器产品</p>	 <p>(顶视图)</p>	 <p>(顶视图)</p>		<p>金属卡簧 18FF-H2 (成对配合使用)</p>
<p>18FF-4Z-C4</p>  <p>螺钉式引出端、 导轨式或螺钉式安装、 带手指保护结构 适用于四组的继电器产品</p>	 <p>(顶视图)</p>	 <p>(顶视图)</p>		<p>塑料卡簧 18FF-H4 金属卡簧 18FF-H5 标识板 18FF-M1 插入式模块 HFAA ~ HFHU*</p>
<p>18FF-4Z-C5</p>  <p>螺钉式引出端、 导轨式或螺钉式安装、 带手指保护结构 适用于四组的继电器产品</p>	 <p>(顶视图)</p>	 <p>(顶视图)</p>		<p>塑料卡簧 18FF-H4 金属卡簧 18FF-H5 标识板 18FF-M1 插入式模块 HFAA ~ HFHU*</p>

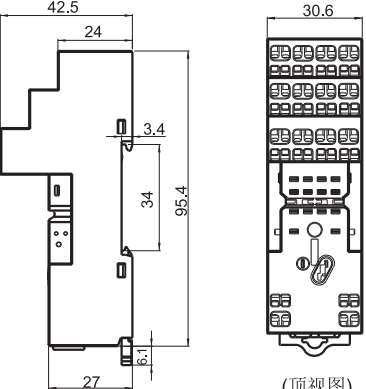
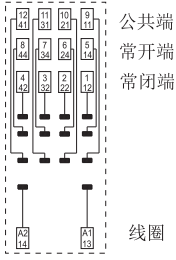
外形图、接线图、安装孔尺寸

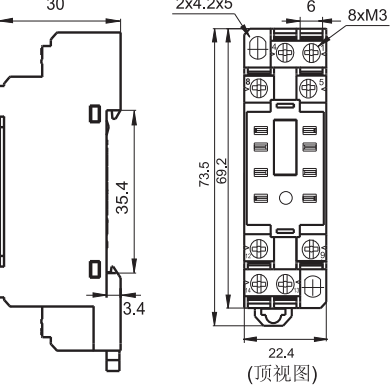
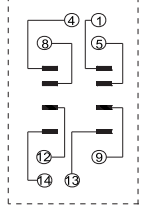
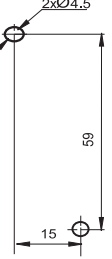
单位: mm

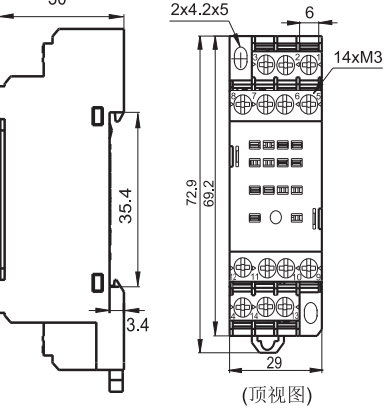
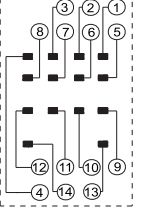
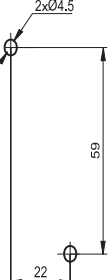
插座	外形尺寸	接线图	安装孔尺寸	可选配件
<p>18FF-4Z-C8</p>  <p>螺钉式引出端、 导轨式或螺钉式安装、 带手指保护结构 适用于四组的继电器产品</p>	 <p>(顶视图)</p>	 <p>(顶视图)</p>		<p>塑料卡簧 18FF-H4 金属卡簧 18FF-H5 标识板 18FF-M3 插入式模块 HFAA ~ HFHU*</p>
<p>18FF-4Z-C9</p>  <p>弹簧式引出端、 导轨式安装、 带手指保护结构 适用于四组的继电器产品</p>	 <p>(顶视图)</p>	 <p>(顶视图)</p>		<p>塑料卡簧 18FF-H4 金属卡簧 18FF-H5 插入式模块 HFAA ~ HFHU* 标识板 18FF-M3</p>
<p>18FZ-2Z-C2</p>  <p>螺钉式引出端、 导轨式或螺钉式安装、 带手指保护结构</p>	 <p>(顶视图)</p>	 <p>(顶视图)</p>		<p>金属卡簧 18FF-H2 (成对配合使用)</p>
<p>18FZ-4Z-C2</p>  <p>螺钉式引出端、 导轨式或螺钉式安装、 带手指保护结构</p>	 <p>(顶视图)</p>	 <p>(顶视图)</p>		<p>金属卡簧 18FF-H2 (成对配合使用)</p>

备注: * 如需选用插入式模块, 请参考对应的产品说明书。

卡簧

18FF-H1(金属卡簧)

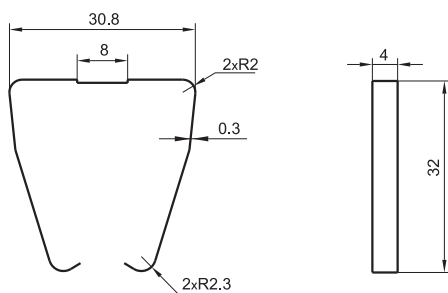

18FF-H2(金属卡簧)

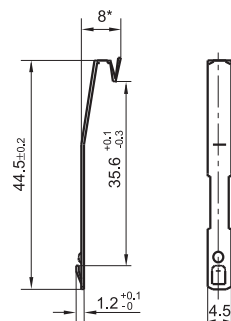

备注: 18FF-H2卡簧须成对配合使用, 订购时请特别注意。

18FF-H4 (塑料卡簧)

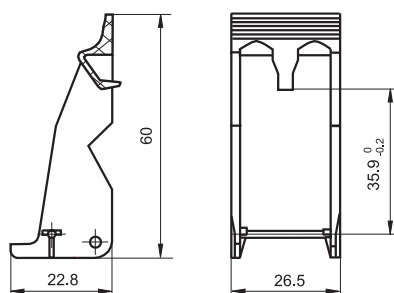

18FF-H5 (金属卡簧)

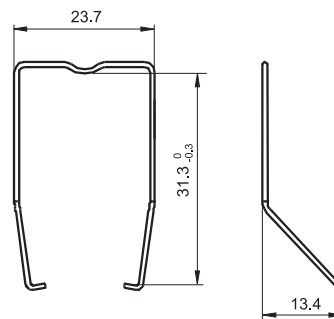

标识板

18FF-M1

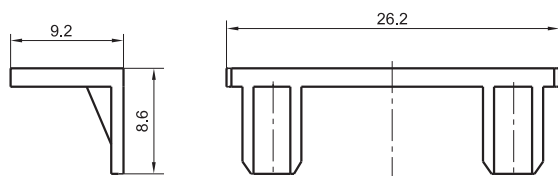

18FF-M3

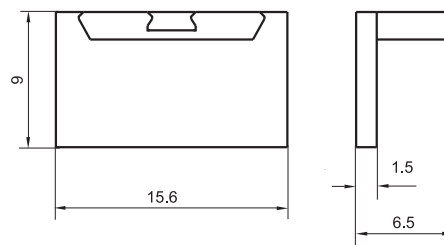

配件选用表

继电器型号	面板结构	插座型号	卡簧型号	标识板	模块	
HF18FF/□□-2Z1□□□	无按钮型	18FF-2Z-A2	18FF-H1	-	-	
		18FF-2Z-C1	18FF-H2			
		18FF-2Z-C2				
		18FZ-2Z-C2				
		18FF-2Z-C4	18FF-H4/H5	18FF-M1	HFAA~HFHU	
		18FF-2Z-C5				
		18FF-2Z-C8				
18FF-2Z-C9		18FF-M3				
18FF-3Z-C4		18FF-M1				
18FF-3Z-C5						
HF18FF/□□-3Z1□□□						
HF18FF/□□-4Z1□□□	无按钮型	18FF-4Z-A2	18FF-H1	-	-	
		18FF-4Z-C1	18FF-H2			
		18FF-4Z-C2				
		18FZ-4Z-C2				
		18FF-4Z-C4	18FF-H4/H5	18FF-M1	HFAA~HFHU	
		18FF-4Z-C5				
		18FF-4Z-C8				
18FF-4Z-C9		18FF-M3				
18FF-2Z-C4		18FF-H4/H5		18FF-M1		HFAA~HFHU
18FF-2Z-C5						
18FF-2Z-C8						
18FF-2Z-C9	18FF-M3					
18FF-3Z-C4						
18FF-3Z-C5						
18FF-4Z-C4	18FF-M1					
18FF-4Z-C5						
18FF-4Z-C8						
18FF-4Z-C9	18FF-M3					
HF18FH/□□-2Z1□□□	带按钮型	18FF-2Z-C4	18FF-H4/H5	18FF-M1	HFAA~HFHU	
HF18FH/□□-3Z1□□□		18FF-2Z-C5				
		18FF-2Z-C8				
		18FF-2Z-C9		18FF-M3		
HF18FH/□□-4Z1□□□		18FF-3Z-C4		18FF-M1		
		18FF-3Z-C5				
		18FF-4Z-C4				
		18FF-4Z-C5				
HF18FH/□□-4Z1□□□		18FF-4Z-C8		18FF-M1		
		18FF-4Z-C9				
	18FF-2Z-C1(734)	18FF-H2	-	-		
	18FF-2Z-C2(734)					
HF18FF-G/□□-2Z1□□□	无按钮型	18FF-2Z-C4(734)	18FF-H4/H5	18FF-M1	HFAA~HFHU	
HF18FF-G/□□-3Z1□□□		18FF-2Z-C5(734)				
		18FF-3Z-C5(734)				
HF18FH-G/□□-2Z1□□□		18FF-2Z-C5(734)				
HF18FH-G/□□-3Z1□□□	带按钮型	18FF-3Z-C5(734)				

选配插座时的注意事项:

1. 请根据实际安装环境、继电器触点组数和继电器引出脚脚位选择合适的继电器插座，选型过程中如有疑问，请与宏发联系以便获取更多的技术支持；
2. 可安装标识卡的插座标配1个标识板，其他相关配件均须另外选配，请您在订货时，务必分别注明挑选的继电器插座及相关配件的型号；
3. 以上仅列举了适用于HF18FF继电器产品的典型插座和相关配件型号，如有特殊要求，请与我们联系；
4. 主要外形尺寸，当外形尺寸>50mm时，公差为±1mm；当20mm<外形尺寸≤50mm之间时，公差为±0.5mm；当5mm<外形尺寸≤20mm之间时，公差为±0.4mm，当外形尺寸≤5mm时，公差为±0.3mm；
5. 导轨安装时，建议使用DIN标准35x7.5x1、35x15x1的标准导轨。

声明:

本产品规格书仅供客户使用时参考，其中未明确规定的要求条件，详见“继电器术语解释及使用指南”。若有更改，恕不另行通知。
对宏发而言，不可能评定继电器在每个具体应用领域的所有性能参数要求，因而客户应根据具体的使用条件选择与之相匹配的产品，如有疑问，请与宏发联系以便获取更多的技术支持。但产品选型责任仅由客户负责。